

4

3

2

1

REVISIONS				
ZONE	REV	DESCRIPTION	DATE	APPROVED

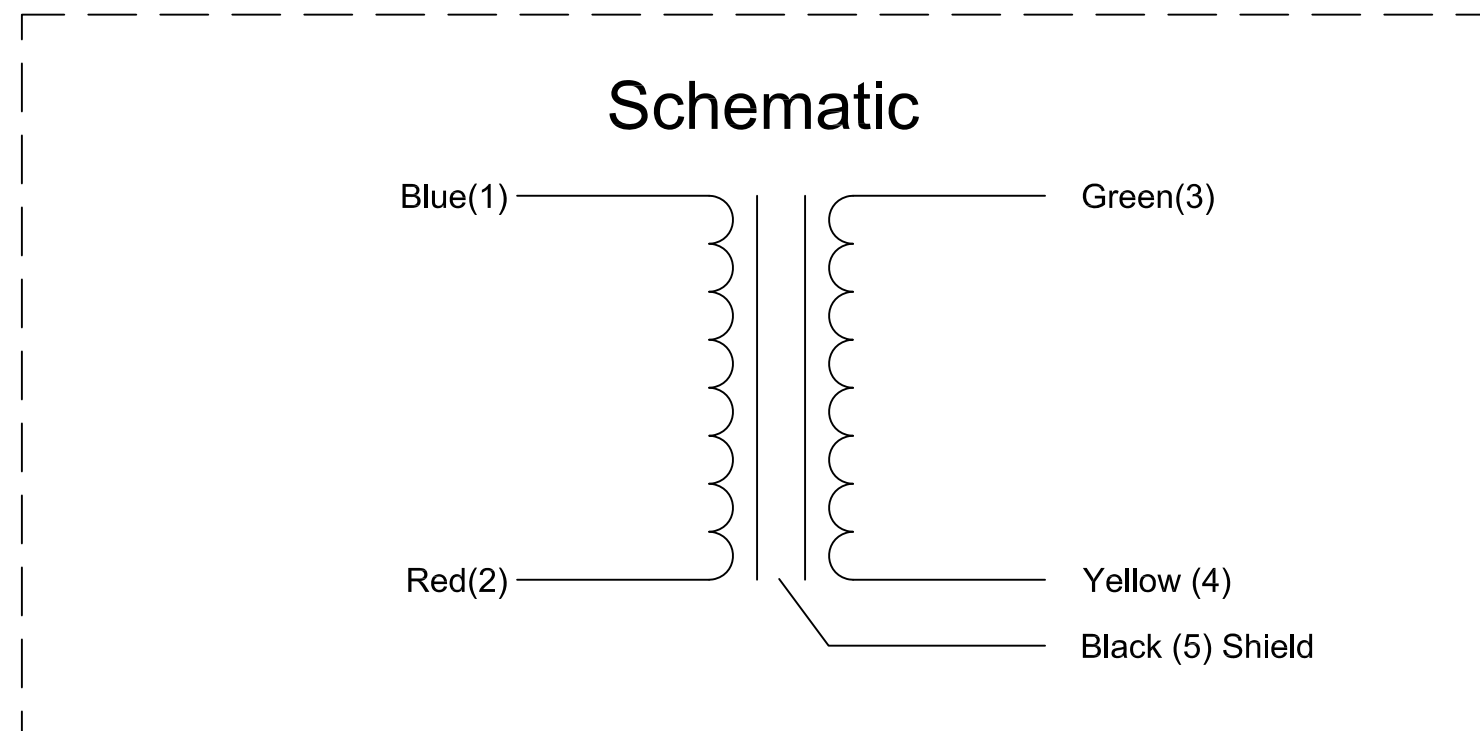
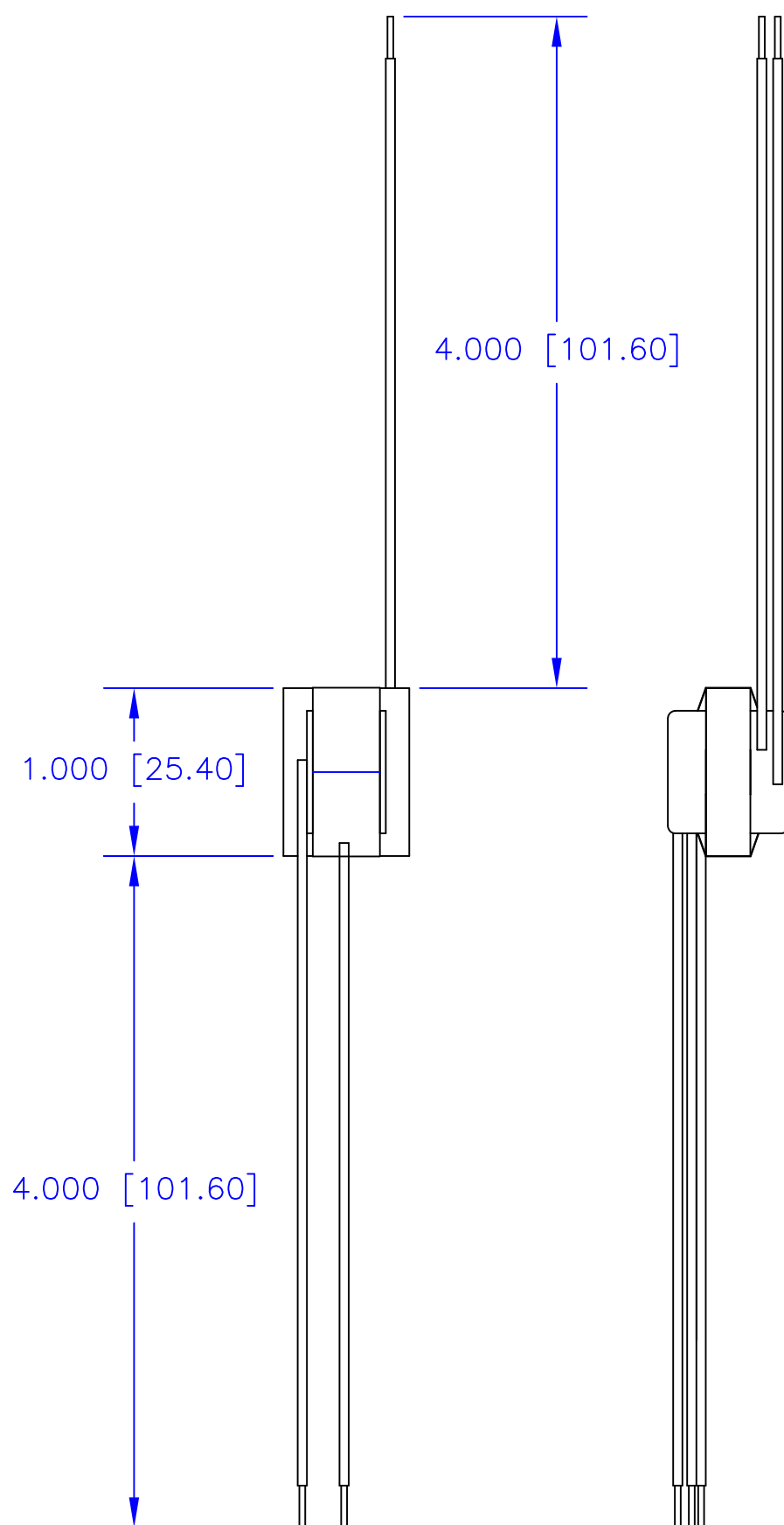
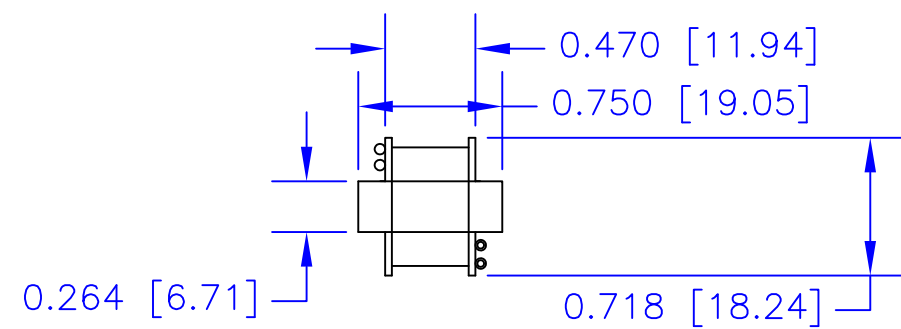

**\*\*NOTES: UNLESS OTHERWISE SPECIFIED!**

1. All material is UL listed.
2. All material are to be RoHS compliant.
3. Bobbin: Nylon 6/6 30% glass filled, Class B, Flammability 94HB UL E184262.
4. Magnet Wire: Class B, UL E32638, Gauge depending on the transformer design specifications requirement.
5. Finish Tape: Polyester film tape, Class 130°, dielectric strength 5000 volts, UL E17385, guide OANZ2.
6. Core Material: Supper "Q" 80 nickel (80%).
7. Termination: 4", UL1007 24 ga. stranded lead wire.
8. Finish: Styrenated alkyd electrical varnish, air cured, UL E63933.
9. Outer copper shielded.

DIMENSIONS ARE IN INCHES (MILLIMETERS). X.XXX = ±0.010 X.XX = ±0.03 ANGLES = ±0.05 UNLESS OTHERWISE SPECIFIED		<b>EDCOR Electronics</b> 7130 National Parks Highway, Carlsbad, NM 88220 Voice: (575)887-6790 Fax: (575)887-6880 <a href="http://www.edcorusa.com">www.edcorusa.com</a>		
DRAWING BY <b>Brian Weston</b>		Date <b>7/2005</b>		
CHECKED BY <b>Brian Weston</b>		Date <b>7/2005</b>		
APPROVED BY <b>Larry Weston</b>		Date <b>7/2005</b>		
SIZE	FSCM NO.	DWG NO.	REV	
<b>C</b>		<b>15000-EI025-025-R01</b>		
SCALE: 1:1		©2010 EDCOR Electronics	SHEET: 1 of 1	

4

3

2

1